

**COMMUNICATIONS
ALLIANCE LTD**



INDUSTRY GUIDELINE
MOBILE NUMBER PORTABILITY-
NETWORK PLAN FOR SMS
G565:2018

G565:2018 Mobile Number Portability – Network Plan for SMS

First published as ACIF G565:2001

Second edition as G565:2009

Third edition as G565:2018

Disclaimers

- 1) Notwithstanding anything contained in this Industry Guideline:
 - a) Communications Alliance disclaims responsibility (including where Communications Alliance or any of its officers, employees, agents or contractors has been negligent) for any direct or indirect loss, damage, claim, or liability any person may incur as a result of any:
 - i) reliance on or compliance with this Industry Guideline;
 - ii) inaccuracy or inappropriateness of this Industry Guideline; or
 - iii) inconsistency of this Industry Guideline with any law; and
 - b) Communications Alliance disclaims responsibility (including where Communications Alliance or any of its officers, employees, agents or contractors has been negligent) for ensuring compliance by any person with this Industry Guideline.
- 2) The above disclaimers will not apply to the extent they are inconsistent with any relevant legislation.

Copyright

© Communications Alliance Ltd 2018

This document is copyright and must not be used except as permitted below or under the *Copyright Act 1968*. You may reproduce and publish this document in whole or in part for your or your organisation's own personal or internal compliance, educational or non-commercial purposes. You must not alter or amend this document in any way. You must not reproduce or publish this document for commercial gain without the prior written consent of Communications Alliance.

Organisations wishing to reproduce or publish this document for commercial gain (i.e. for distribution to subscribers to an information service) may apply to subscribe to the Communications Alliance Publications Subscription Service by contacting the Communications Alliance Commercial Manager at info@commsalliance.com.au. If you publish any part of this document for any purpose, you must also publish this copyright notice as part of that publication.

TABLE OF CONTENTS

1	INTRODUCTION	2
	1.1 Introduction of MNP	2
	1.2 Number Portability for Mobile Numbers	2
	1.3 Scope	2
	1.4 Routing principles	3
	1.5 2009 Revision	4
	1.6 2018 Revision	4
2	ACRONYMS	5
	2.1 Acronyms	5
3	SHORT MESSAGE SERVICE	7
	3.1 General	7
4	SM DELIVERY VIA 3GPP MAP	8
	4.1 General	8
	4.2 Routing principles	9
	4.3 Addressing across point of interconnection	10
	4.4 Prevention of circular routing	10
	4.5 Error codes	10
5	REFERENCES	11
	PARTICIPANTS	12

1 INTRODUCTION

1.1 Introduction of MNP

Number portability for mobile numbers was implemented in Australia in accordance with the ACMA *Telecommunications Numbering Plan 1997*, the Australian Competition and Consumer Commission's (ACCC's) directions to the Australian Communications Media Authority (ACMA) and the implementation date of 25th September 2001 set by the ACMA.

1.2 Number Portability for Mobile Numbers

- 1.2.1 Mobile Number Portability (MNP) is the ability for a customer to change mobile Carriage Service Provider (CSP) and/or mobile Carrier whilst retaining their mobile number.
- 1.2.2 Under MNP only the mobile number is ported. The basic and supplementary services provisioned in the recipient network are not dependent on those that were provisioned in the losing network.
- 1.2.3 As a consequence of MNP, the Terminating Access Service Deliverer (TASD) can not be reliably determined from the number range allocated to a mobile CSP.
- 1.2.4 Routing of voice, data and fax in the MNP environment is specified in the **Network Plan for Voice, Data and Fax Services** Guideline (G561:2009), which allows for a combination of donor routing and direct routing. Although these routing methodologies will ensure end to end connectivity for those types of mobile communication, the Short Message Service requires a separate plan because short messages are routed differently from voice calls.

1.3 Scope

- 1.3.1 There is currently no regulatory requirement to provide inter-carrier SMS. Intercarrier SMS is established through commercial arrangements on a bilateral basis. This plan specifies industry agreed routing arrangements and error code treatment to enable correct delivery of inter-carrier Short Message (SM) under mobile number portability. The plan applies only to inter-carrier messages which are communicated via Third Generation Partnership Project (3GPP) MAP signalling between mobile digital networks that conform to 3GPP standards. Changes to these international standards or the deployment of a different mobile network technology may give rise to a need to revise this plan.
- 1.3.2 This SMS network plan provides:
 - (a) support for full intra- and inter-technology SMS for portable mobile numbers;
 - (b) support for incoming international SMS to portable mobile numbers;

- (c) support for national and international roaming;
 - (d) for the treatment of error cases;
 - (e) for the prevention of circular routing.
- 1.3.3 This plan does not require any modification to the 3GPP MAP protocol. An item not specified in this plan that needs to be specified and agreed via bilateral agreement is addresses of network elements not publicly available (applicable to 3GPP MAP);
- 1.3.4 Charging capabilities are outside the scope of this plan.

1.4 Routing principles

- 1.4.1 The SMS routing principles recommended in this Plan ensure that inter-carrier short messages are delivered to the correct T ASD in the MNP environment.
- 1.4.2 This plan specifies two routing mechanisms:
- (a) Direct routing for a SM originated from an SMSC that forms part of an Australian PLMN; and
 - (b) Donor routing for a SM originated from an SMSC that does not form part of an Australian PLMN.

Direct routing requires the Originating Access Service Deliverer (OASD) to determine the correct Terminating Access Service Deliverer (TASD) and to route the SM accordingly.

Donor routing means the OASD routes the SM query to the donor network (Carrier assigned by the CSP that has been allocated the number block by the ACMA).

- 1.4.3 Connectivity for SMS and compatibility of protocols between all parties involved in donor routing cannot be guaranteed. Therefore, direct routing between the OASD and the correct T ASD must be supported wherever bilateral agreements for national inter-carrier SMS exist.
- 1.4.4 Where internationally originated SMS is supported donor routing must be supported wherever bilateral agreement exists for the national leg, as international networks are not likely to access an Australian mobile number portability database prior to routing the message. However, certain limitations apply – see Appendix A.
- 1.4.5 A SMS Transit Service Deliverer (STrSD) can be contracted by any CSP in order to fulfil requirements of this plan. It is the responsibility of the contracting CSP to ensure that any STrSD employed is compliant with this plan.
- 1.4.6 A STrSD is contracted by an OASD to determine the T ASD for portable number ranges and route messages accordingly. A STrSD may also be contracted by a T ASD to deliver messages to the network of the T ASD. The same or different STrSD may be used

to deliver messages to and from the network. Any CSP can act as a STrSD. The OASD and the STrSD may agree that their contractual arrangement will apply to a subset of all mobile number ranges. An OASD may use more than one STrSD.

- 1.4.7 For the purpose of this plan, where a STrSD is used by OASD or TASD, the network of the STrSD and the OASD or TASD (as applicable) are regarded as a single virtual network. The STrSD and the OASD or TASD (as applicable) using its services must ensure circular routing does not occur.
- 1.4.8 The TASD must not transit a nationally originated SM whether delivered via the STrSD or directly from the OASD.
- 1.4.9 No additional routing arrangements are required for national or international roaming.

1.5 2009 Revision

In 2009, the Mobile Number Portability Code was revised. At that time all associated Mobile Number Portability documents were republished as Communications Alliance documents to reflect the change of organisational name from ACIF. Where relevant any references to other documents have also been updated.

1.6 2018 Revision

In 2018, two new entrants were planning to undertake testing to participate in the Mobile Number Portability environment, so the document was updated to reflect current network technology.

2 ACRONYMS

2.1 Acronyms

3GPP

Third Generation Partnership Project

ACCC

Australian Competition and Consumer Commission

ACIF

Australian Communications Industry Forum

ACMA

Australian Communications and Media Authority

CCS

Common Channel Signalling

CSP

Carriage Service Provider

ESME

External Short Message Entity

HLR

Home Location Register

IMSI

International Mobile Subscriber Identity

MAP

Mobile Application Part

MNP

Mobile Number Portability

MSC

Mobile Switching Centre

MSISDN

Mobile Station ISDN Number

OASD

Originating Access Service Deliverer

PDU

Protocol Data Unit

PLMN

Public Land Mobile Network

POI

Point Of Interconnection

SM

Short Message

SMS

Short Message Service

SMSC

Short Message Service Centre

STrSD

SMS Transit Service Deliverer

TASD

Terminating Access Service Deliverer

TCP/IP

Transmission Control Protocol / Internet Protocol

VLR

Visitor Location Register

3 SHORT MESSAGE SERVICE

3.1 General

- 3.1.1 The Point-to-Point SMS provides a means of sending messages of limited size to a mobile customer. The provision of SMS makes use of a Short Message Service Centre (SMSC), which may function as a store and forward centre for short messages.
- 3.1.2 Mobile terminated SM denotes the capability of a SMSC to transfer a SM to a mobile customer and be provided with the information about the delivery status of the SM. This is achieved typically by a delivery report or a failure report with a specific mechanism for later delivery.
- 3.1.3 Unsuccessful message transfer from the SMSC to a mobile customer may be caused by a variety of different errors. Errors are either permanent or temporary in nature. For permanent errors no further attempts are made to deliver the message to the mobile customer. Temporary errors may result in subsequent delivery attempts.

4 SM DELIVERY VIA 3GPP MAP

In GSM MAP responsibility for SM delivery to a mobile customer lies at all times with the originating SMSC and cannot be passed to any other SMSC.

4.1 General

4.1.1 The general architecture for inter-carrier SMS via 3GPP MAP is shown in the Figures 1 and 2, and can be used in any of the following cases:

- (a) National mobile network to national mobile network (Figure 1)
- (b) International mobile network to national mobile network (Figure 2)

4.1.2 Of the 3GPP MAP messages used to send an SM, two are affected by MNP – `sendRoutingInfoForShortMsg` and `setMessageWaitingData`, as these rely on the MSISDN for addressing.

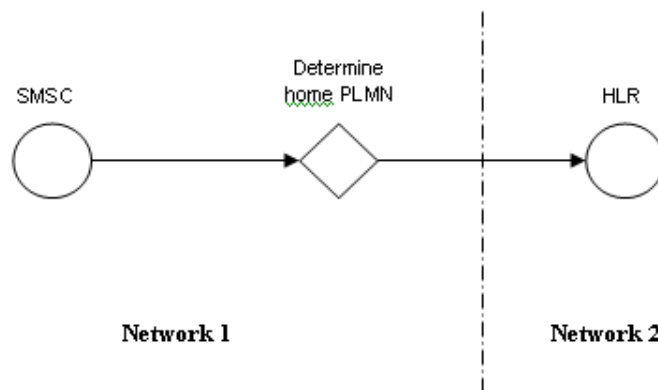

FIGURE 1
Direct Routing

NOTE: The OASD determines the correct home PLMN

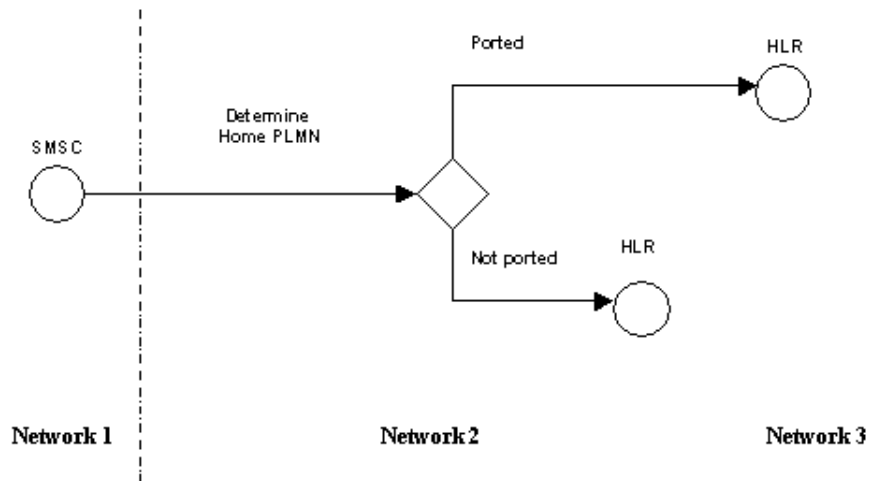

FIGURE 2
Donor Based Routing

NOTE: The OASD routes the affected signalling messages to the donor network (the network assigned by the CSP that has been allocated that number block by the ACMA), which will determine the correct home PLMN.

4.2 Routing principles

- 4.2.1 The 3GPP MAP routing principles will ensure that under a MNP environment:
- (a) messages are routed directly to the correct recipient network (for nationally originated SMS);
 - (b) messages are routed to the network holding the number block allocation of the destination number (only for internationally originated SMS); and
 - (c) circular routing is avoided.
- 4.2.2 The plan presumes that messages originated from an international network to ported numbers (see Clause 4.1) will be delivered via donor-based routing, as international networks cannot be expected to access an Australian mobile number portability database prior to routing the message.
- 4.2.3 The type of routing applicable to a particular traffic case is shown in Table 1.

TABLE 1
3GPP MAP Routing Cases

Traffic case	Donor based routing	Direct routing
National mobile network to national mobile network	No	Yes
International mobile network to national mobile network	Yes	No

- 4.2.4 It should be noted that a customer with a ported number will be able to receive an internationally originated SM only from the common international roaming partners of the donor and recipient network, where connectivity between donor and recipient exists – see Appendix A.

4.3 Addressing across point of interconnection

- 4.3.1 The number structure used for the addressing across the Point of Interconnection (POI) must be in the international format as defined in ITU-T Recommendation E.164.

4.4 Prevention of circular routing

- 4.4.1 It is necessary to guard against the possibility that the porting data for a mobile number is inconsistent between databases used for routing in different networks. In-bound `sendRoutingInfoForShortMsg` and `setMessageWaitingData` messages addressed to a number that does not belong to a mobile CSP's allocated number block must not be transited to another network.

4.5 Error codes

- 4.5.1 Unsuccessful SM delivery may be caused by a variety of different errors. Error treatment in general will follow the pertinent specification ETSI TS 123 040.
- 4.5.2 Two cases arise where unsuccessful delivery is due to the implementation of MNP. The error codes that apply to each case are as follows:
- (a) SM delivery to a mobile number ported to a network where there is no inter-carrier SMS connectivity will be unsuccessful. The error code to be returned to the originating SMSC shall be any permanent error code from the pertinent specification.
 - (b) Due to the misalignment of data in routing databases, `sendRoutingInfoForShortMsg` and `setMessageWaitingData` message may be delivered to the wrong network after the originating network has performed a lookup. The receiving network can deal with the error on either MAP or SCCP level. The MAP level error treatments must follow ETSI TS 123 040. The SCCP level error treatment must follow ITU-T SCCP suite of specifications (Q.711 to Q.714).

5 REFERENCES

Publication	Title
Industry Codes	
C570:2009 Incorporating Amendment No.1/2015	Mobile Number Portability
Industry Guidelines	
G561:2009	Mobile Number Portability - Network Plan for Voice, Data and Fax Services
ETSI Standard	
ETSI TS 123 040 V15.1.0 (2018-06)	Digital cellular telecommunications system (Phase 2+); Universal Mobile Telecommunications System (UMTS); Technical realization of the Short Message Service (SMS) (3GPP TS 23.040 version 15.1.0 Release 15) https://www.etsi.org/deliver/etsi_ts/123000_123099/123040/15.01.00_60/ts_123040v150100p.pdf
International Telecommunications Union	
E.164 (11/2010)	The international public telecommunication numbering plan https://www.itu.int/itu-t/recommendations/rec.aspx?rec=10688
Q.713 (03/2001)	Signalling Connection Control Part formats and codes https://www.itu.int/itu-t/recommendations/rec.aspx?rec=5411

PARTICIPANTS

The Network Reference Panel, constituted as a Working Committee, responsible for the revisions made to this Guideline consisted of the following organisations and their representatives:

Organisation	Membership	Representative
ACCC	Non-voting	James Park
ACMA	Non-voting	Cuong Nguyen
Optus	Voting	Sam Mangar
Telstra	Voting	Guy Di Paola
Telstra	Non-voting	Peter Cooke
Vodafone Hutchison Australia	Voting	Angus Clearie

This Working Committee was chaired by Mike Elsegood. James Duck of Communications Alliance provided project management support.

Communications Alliance was formed in 2006 to provide a unified voice for the Australian communications industry and to lead it into the next generation of converging networks, technologies and services.

In pursuing its goals, Communications Alliance offers a forum for the industry to make coherent and constructive contributions to policy development and debate.

Communications Alliance seeks to facilitate open, effective and ethical competition between service providers while ensuring efficient, safe operation of networks, the provision of innovative services and the enhancement of consumer outcomes.

It is committed to the achievement of the policy objective of the *Telecommunications Act 1997* - the greatest practicable use of industry self-regulation without imposing undue financial and administrative burdens on industry.



**Published by:
COMMUNICATIONS
ALLIANCE LTD**

**Level 9
32 Walker Street
North Sydney
NSW 2060 Australia**

**Correspondence
PO Box 444
Milsons Point
NSW 1565**

**T 61 2 9959 9111
F 61 2 9954 6136
TTY 61 2 9923 1911
E info@commsalliance.com.au
www.commsalliance.com.au
ABN 56 078 026 507**

Care should be taken to ensure the material used is from the current version of the Industry Guideline and that it is updated whenever the Industry Guideline is amended or revised. The number and date of the Industry Guideline should therefore be clearly identified. If in doubt please contact Communications Alliance